

Benchmark® Biometric Sensor System for Wearable Devices

Features

- Market- quality optical heart rate (HR) measurement, step rate / count, distance, cycling cadence, calories, R-R interval (RRi) and activity recognition (running/lifestyle)
- Single Benchmark module simplifies system integration
- Sensor module contains processor, LED, detector, and accelerometer mounted to an IR-filtering window assembly optimized for sensor system accuracy
- PerformTek® Low-Power ARM® Cortex® processor performs sensor data processing and provides a communication interface to the system host processor.

- Field updatable processor firmware
- Patented optomechanical designs
- 100% factory-tested
- Additional design and test services available upon request

Description

The PerformTek powered Benchmark Wrist 1.4 Sensor System is the next-generation biometric wearable sensor technology developed by Valencell, Inc. This sensor helps you quickly develop your own biometric products. The modular design brings together the best available parts of a successful biometric sensor system in a smaller form factor and includes emitter/detector sensor electronics in an optimized optical package with a processor that is pre-programmed with Valencell's PerformTek advanced biometric algorithms.

Figure 1: Benchmark Wrist 1.4 Sensor

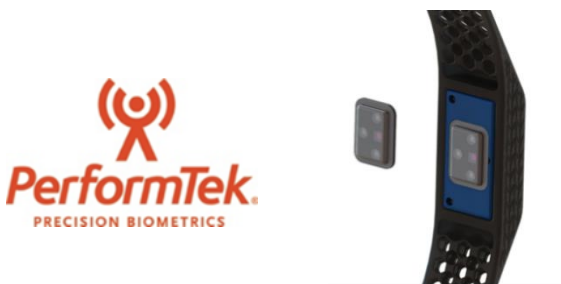

- Wrist Sensor Dimensions: (19.5 x 14.5 x 3.56) mm
- Sensor Weight: 0.85 grams
- Pressure Rating: 5 ATM
- 400 kHz I2C or 57.6 kbps UART Interface
- RoHS / REACH / Halogen Free
- Sensor V_{DD} : 1.8 VDC to 3.3 VDC / V_{LED} : 5 VDC
- V_{LED} Current: 170 μ A Continuous Average
- V_{DD} Current: 270 μ A @1.8VDC / 285 μ A @3.3VDC average operating

Figure 2: Benchmark Wrist 1.4 Simplified Block Diagram

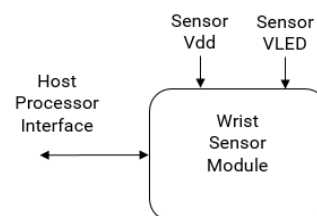

Applications

- Wearable Devices
- Lifestyle / Activity Bands
- Smart Watches
- Wrist, Forearm, and Upper Arm Bands for Sports
- Helmets and Headbands

Reference Documentation

Table 1: Related Documents

Document	Title
001902	BW1.4 Integration Dimensions and CAD
000638	PerformTek Interface Protocol Document
000964	PerformTek User Guide
000832	PerformTek Wrist Integration Guide
001569	PeformTek Migration Guide Gen 1 to Gen 2

Change Record

Table 2: Change Record

Author	Revision	Date	Description of change(s)
MEP	01.00	01FEB2019	Initial Release (Preliminary Datasheet)
MEP	01.01	07AUG2019	Updates based on design finalization / Removed "Preliminary" marking

Table of Contents

1	Block Diagram / System Overview	4
2	Sensor Pin Descriptions	5
2.1	Sensor Pinout	5
2.2	Sensor Connector Description	6
3	Sensor Electrical Characteristics	7
4	PerformTek Sensor Connections and Features	11
5	Sensor Power Supply Design Guidelines	13
5.1	Power Supply Loading	13
5.2	Power Supply Sequencing	13
5.3	Power Supply Rise Time	13
5.4	VDD Transients	13
5.5	Power Down Requirements	13
6	Firmware Updates	14
6.1	Firmware Update Interface	14
6.2	Flash Memory Erase Time	14
6.3	Bootloader Protection	14
7	Sensor Optical-Mechanical Integration	15
8	Processor Communication Interface Example	16
9	Sensor Ordering Guide	17
10	Valencell Product Development Design and Test Services	18
11	Contact Information	19
12	Statements	20

1 Block Diagram / System Overview

Figure 3 shows a high-level block diagram of the Benchmark Wrist 1.4 Biometric Sensor plus associated interface signals.

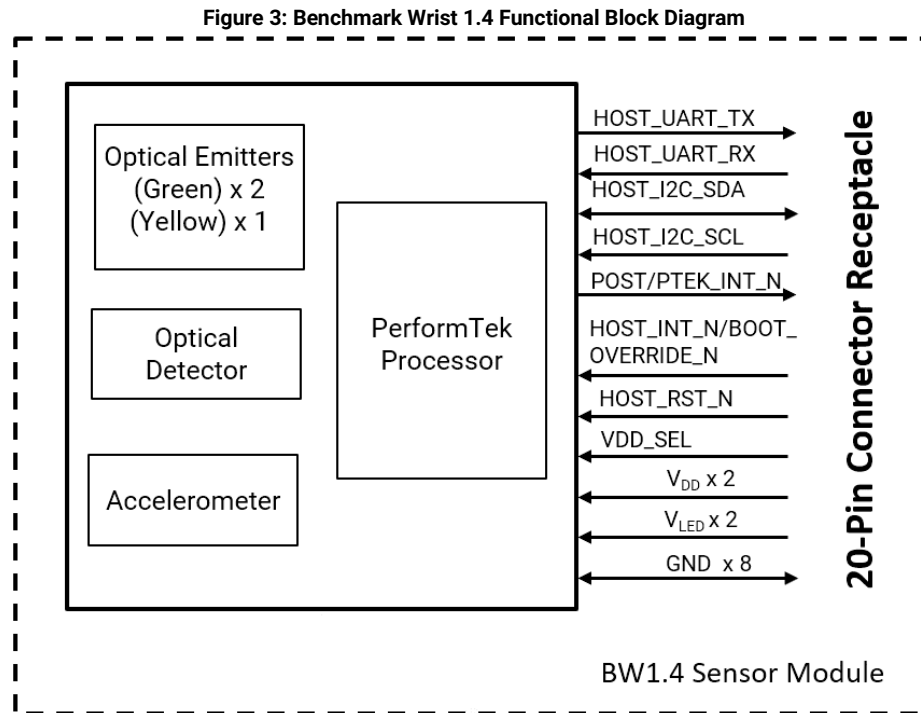

The sensor module circuit board contains a digital optical detector system, three LEDs, and an accelerometer. The detector, LEDs, and accelerometer work together to collect biometric information via reflected light and movement from the wearer. The integrated low power, PerformTek processor controls the sensing devices over the internal I2C bus.

The integrated PerformTek processor collects the sensor data and runs Valencell’s patent protected algorithms to convert the raw measurements into biometric values such as heart rate or cadence and processes those values further into higher level user assessments like calories burned. In addition, sensor module diagnostics such as signal quality, error codes, and serial number ID are available. This information is available to the Host processor via the Host Interface.

The Host Interface is shown on the right side of the diagram. Control lines for interfacing the host processor with the PerformTek processor include UART or I2C and other discrete control lines.

2 Sensor Pin Descriptions

2.1 Sensor Pinout

Table 3 and Figure 4 show the pinout for the sensor. Figure 5 shows an image of the BW1.4 Sensor Connector Orientation.

Table 3: Sensor Connector Pinout

Pin	Name	I/O	Description
1, 2, 9, 10, 11, 12, 19, 20	Input / Output	GND	Connect to system ground / reference plane
3, 4	Input	V _{DD}	VDD Sensor Power Input. Connect to sensor supply voltage.
5, 6	Input	V _{LED}	LED Power Input. Connect to V _{LED} supply voltage.
7	Output	HOST_UART_TX	MCU Host (Slave) Interface: UART TX to Host from MCU
8	Output	POST/PTEK_INT_N	MCU Host (Slave) Interface: Active High POST Indicator Active Low PTEK Interrupt
13	Input / Output	HOST_I2C_SDA	PerformTek Host (Slave) I2C Interface
14	Input	HOST_INT_N/BOOT_OVERRIDE_N	MCU Host (Slave) Interface: Active low HOST_INT and Active low BOOT_OVERRIDE
15	Input	HOST_I2C_SCL	PerformTek Host (Slave) I2C Interface
16	Input	HOST_RST_N	MCU Reset
17	Input	HOST_UART_RX	MCU Host (Slave) Interface: UART RX from Host to MCU
18	Input	VDD_SEL	VDD_SEL = GND: LDO On, RX_SUP >=2V VDD_SEL = VDD: LDO Off, RX_SUP = 1.8 to 1.9V

2.2 Sensor Connector Description

The BW1.4 sensor interface uses a Hirose BM20B(0.6)-20DS-0.4V(51) connector as shown in Figure 5. Pin 1 of the connect is on the bottom, left side of the connector as viewed in Figure 5 and is indicated by a white dot on the PCBA. A Hirose BM20B(0.6)-20DP-0.4V(51) or equivalent connector should be used on the system host side to interface to it.

Note: The BW1.4 sensor interface and associated pinout was designed to be as close as possible to the BW1.2. Key differences between the BW1.4 and BW1.2 sensor interfaces are that the UART and I2C interfaces are now physically separated and the VDD_SEL and HOST_RST_N pins have been added. See Section 4 for more details.

Figure 4: Benchmark Wrist 1.4 Connector

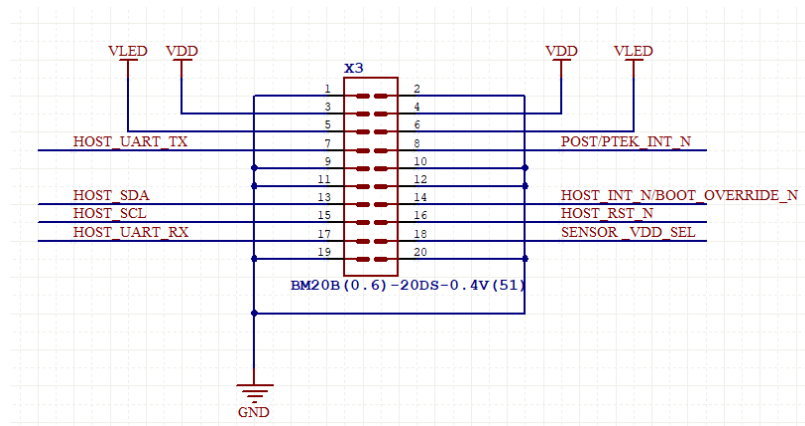
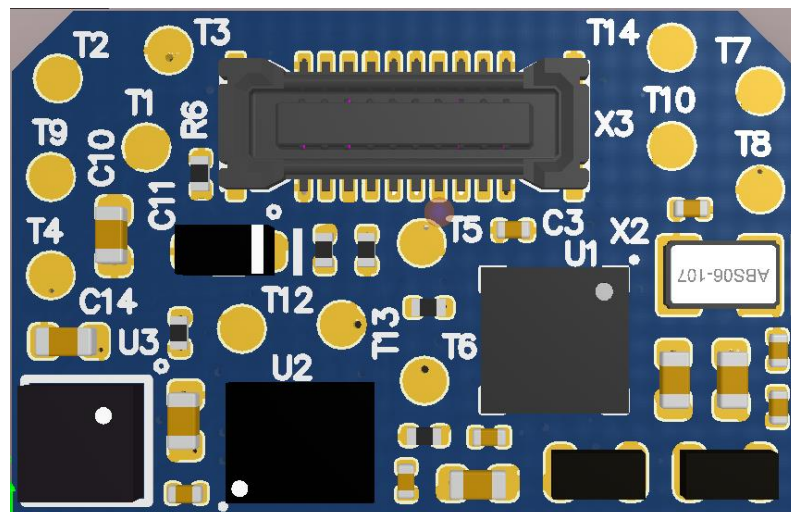

Figure 5: Preliminary Benchmark Wrist 1.4 Sensor Image



3 Sensor Electrical Characteristics

Table 4: Recommended Operating Conditions for Sensor

Parameter	Symbol	Conditions	Min	Typ	Max	Units
V _{LED} Supply Voltage	V _{LED}	Min and Max are inclusive of V _{LED} ripple requirement	4.875	5.0	5.25	VDC
V _{LED} Ripple	V _{ripple}	Sensor system active	---	---	250	mV _{pp}
Sensor Supply Voltage (Low-Range)	V _{DD(SENSE_LOW)}	Requires VDD_SEL to be pulled high to disable the sensor's on-board LDO. In this mode of operation, the sensor is more sensitive to VDD power supply noise. Note: V _{DD} > 1.9 and V _{DD} < 2.0V not defined	1.8	1.85	1.9	VDC
Sensor Supply Voltage (High-Range)	V _{DD(SENSE_HIGH)}	Requires VDD_SEL to be pulled low to enable the sensor's on-board LDO, otherwise damage may occur. Sensor noise immunity is higher in this operating mode, but sensor power consumption increases as V _{DD} increases.	2.0	2.1	3.6	VDC
Sensor Supply Ripple Voltage	V _{ripple}	Sensor system active	-	-	50	mV _{pp}

Operating Temperature	-	Device operating in Standby, Idle, or Active Modes	-20	25	70	°C
-----------------------	---	--	-----	----	----	----

Table 5: Operating Characteristics of Sensor

Parameter	Symbol	Conditions	Min	Typ	Max	Units
$I_{DD} + I_{LED_SENSOR}$ OFF Mode	-	No V_{DD} supply given to sensor module	-	0	-	μA
I_{DD} Standby Mode	-	System is in Standby mode (currently Idle Mode and Standby mode are the same. Future work may be performed to support a true Standby mode to provide further power savings when sensor is not in use)	-	145	-	μA
I_{DD} Idle Mode	-	$V_{DD} = 1.8VDC$ System is in Idle mode	-	145	-	μA
I_{DD} Active Mode, HR or Standard-Precision RRi^1	-	$V_{DD} = 1.8VDC$ System is in Active mode and operating at standard RRi sampling rate	-	270	-	μA
I_{DD} Active Mode with High-Precision RRi^1	-	$V_{DD} = 1.8VDC$ System is in Active mode and operating at fast RRi sampling rate	-	535	-	μA
I_{DD} Idle Mode	-	$V_{DD} = 3.3VDC$ System is in Idle mode	-	150	-	μA

Parameter	Symbol	Conditions	Min	Typ	Max	Units
I _{DD} Active Mode, HR or Standard-Precision RRI ¹	-	V _{DD} = 3.3VDC System is in Active mode and operating at standard RRI sampling rate	-	285	-	μA
I _{DD} Active Mode with High-Precision RRI ¹	-	V _{DD} = 3.3VDC System is in Active mode and operating at fast RRI sampling rate	-	610	-	μA
I _{LED} Sensor Standby and Idle Modes	-	System is in Standby mode	-	14	-	μA
I _{LED} Sensor Active Mode with Standard-Precision RRI ¹	-	System is in Active mode and operating at standard RRI sampling rate	-	170	-	μA
I _{LED} Sensor Active Mode with High-Precision RRI ¹	-	System is in Active mode and operating at fast RRI sampling rate	-	700	-	μA
I _{LED} LED Pulse Current	-	System is in Active mode	-	1	2	mA
I _{DD} Pulse Current	-	System is in Active mode	-	10	-	mA
Start-up time before POST response	t _{POST}	On Start-up, time measured after V _{DD} equal to or above 1.8V	-	178	250	ms

Note 1: High-Precision operation and current draw applies to RRI only. Best-precision heart rate monitoring is available in standard Active Mode.

Absolute limits are provided below. If these limits are exceeded, permanent device damage may occur. Additionally, if the sensor is exposed to these limits for an extended period of time, the sensor reliability may be impacted.

Table 6: Sensor Absolute Maximum Limits

Parameter	Symbol	Conditions	Min	Typ	Max	Units
Storage Temperature	-	Device powered off, device will require time to equalize with normal operating temperature after exposure to limits of storage temperature	-40	-	85	°C
ESD Rating	-	Human Body Model ¹	-	-	2	kV

Note 1: The sensor module is designed to support system level ESD compliance testing up to 4 kV contact and 8 kV air discharges; however, ESD protection for the standalone sensor module is intended only to protect the sensor during normal handling in a typical electronic manufacturing environment with typical ESD protection in place.

4 PerformTek Sensor Connections and Features

Host Interface – UART / I2C

The Host interface connecting the system processor to the PerformTek processor supports both I2C and UART communications. Either I2C or UART should be connected to the Host since only one interface can be used at a time. The PerformTek processor will automatically detect the active interface. On boot up, the PerformTek processor will scan both communications ports until activity is detected on one of them. For optimal power savings, it is recommended to exercise one of the ports so that the PerformTek processor can shut down the unused port. Additionally, no external pull-up resistors are required for correct operation of the PerformTek MCU I2C port, since it provides internal pull-ups. If pull-ups are required for other devices on the I2C bus while the PerformTek MCU is powered off or in reset, external pull-up resistors may be added. If external pull-ups are added, the interface will consume additional power through the external resistors.

For UART host communications, the HOST_UART_RX pin is the receive line for data sent to the module from the host processor and the HOST_UART_TX pin is the transmit line from the sensor module to the host. The port settings are 57.6 kbps, 8, N, 1. There is no hardware or software flow control.

For I2C host communications, the I2C_SDA line is the data line and I2C_SCL line is the clock line. The sensor module acts as an I2C slave device with up to 400KHz bus speed and a 7-bit I2C address of 0x45. This interface has been updated from previous generations of the PerformTek I2C interface to support the Ambiq lower power interface. For more information about the UART or I2C communication protocols or to see more details on updates associated with the I2C interface, see the PerformTek Interface Protocol Document.

Host Interface – POST / PTEK_INT_N

Once V_{DD} power is applied, the processor will attempt to initialize all components on the module. This startup time is defined by t_{POST} in Table 5. If startup is successful, the POST / PTEK_INT_N pin will assert high, otherwise, the pin will stay low. If the POST pin is not utilized, the Max time for t_{POST} should be observed before interaction with the PerformTek processor begins.

Diagnostic information associated with this pin is stored in the sensor module's registers and can be read via the UART/ I2C Host Interface. As part of the POST, the PerformTek processor tests communications with the sensor peripherals and exercises the axes of the accelerometer while checking for a response within bounds. If a failure is detected but the processor can still communicate, the POST

will still assert high. To ensure correct system operation, the POST_RESULTS register should be examined at startup.

After successful bootup and assertion of the POST status, the POST / PTEK_INT_N provides software configurable interrupt output functionality from the PerformTek processor to the Host.

Refer to the PerformTek Interface Protocol Document for further information on the POST, other diagnostic registers, and interrupt configuration.

Host Interface – HOST_INT_N / BOOT_OVERRIDE_N

Upon application of V_{DD} power or upon release of reset, the PerformTek processor will enter Bootloader mode if HOST_INT_N / BOOT_OVERRIDE_N is asserted low.

During normal operation, HOST_INT_N / BOOT_OVERRIDE_N provides software configurable interrupt input functionality from the Host to the PerformTek processor.

Host Interface – HOST_RST_N

HOST_RST_N is an active low reset signal connected to the HOST controller to allow it to control reset of the PerformTek processor. Valencell recommends connecting this line to the Host controller as part of a robust system reset strategy.

Note: Current consumption is undefined while the PerformTek processor is held in reset. HOST_RST_N should not be used as a method to hold the PerformTek processor in a low power state. Removing power from the MCU or placing the MCU in Standby mode is the best method for achieving minimum power consumption when the sensor is not in use.

Host Interface – VDD_SEL

For $V_{DD} \geq 2V$, connect VDD_SEL to ground via a 1kOhm resistor

For $V_{DD} = 1.8$ to $1.9V$, connect VDD_SEL to VDD via a 1kOhm resistor

5 Sensor Power Supply Design Guidelines

5.1 Power Supply Loading

Actual peak and average current loading on the system power rails will vary depending on the unique characteristics of the system design and how the PerformTek features are used within the system. Because of this, Valencell recommends testing our sensors in a manner representative of their intended use as early as possible in the design cycle to ensure that the power supply requirements are met. To facilitate this, Valencell supplies development kits that support early prototyping and power measurement and Valencell can provide additional design support and review services upon request.

5.2 Power Supply Sequencing

The system V_{LED} supply should come up at the same time as the V_{DD} supply (within ± 10 ms) to ensure correct sensor operation. Additionally, if either power rail is removed, the other rail should be removed at the same time to prevent excessive leakage currents from occurring.

5.3 Power Supply Rise Time

There are no known issues with fast rise time during power up. However, there are power supply constraints related to power down. See Section 5.5 for more details.

5.4 VDD Transients

Voltage transients greater than 2 kV/s on VDD should be avoided during normal device operation. Small voltage dips <50 mV can be tolerated.

5.5 Power Down Requirements

When power is removed from the sensor, it must drop below 0.3V for at least 200ms before power is reapplied to ensure that the internal MCU analog circuitry properly reinitializes.

6 Firmware Updates

Valencell recommends that all systems be designed to support firmware updates to take advantage of the latest feature updates as they become available. PerformTek MCUs include a bootloader designed to accept encrypted firmware update files (.val files), which are available for download on Valencell's ShareFile site.

6.1 Firmware Update Interface

Firmware updates are delivered to the PerformTek MCU via the Host Interface (UART or I2C) using an XMODEM 1 protocol. See the PerformTek User Guide for more details.

6.2 Flash Memory Erase Time

The PerformTek User Guide indicates that the Host system must add a delay of one to five seconds after the first XMODEM packet is sent to allow time for the PerformTek MCU to erase the existing firmware image. For the PerformTek Low Power MCU, the required delay time is up to 2.5 seconds to support the worst-case erase time of 2.5 seconds while the typical erase time for the Apollo 2 is 0.5 seconds.

6.3 Bootloader Protection

To perform firmware updates, it is necessary for the PerformTek MCU to erase its existing application image. However, the bootloader is protected and will not be erased or over-written. This prevents the PerformTek MCU from becoming "bricked" in case of an improper firmware update attempts. While the bootloader will always be present if an error occurs during firmware updates, a new .val load must be successfully transferred before normal PerformTek operation can be restored.

7 Sensor Optical-Mechanical Integration

The Benchmark sensor housing is a critical component of the sensor module, ensuring optical coupling from the emitters and sensors to the user’s skin. This opto-mechanical system design is necessary for accurate measurement. The PCB and opto-mechanical lens are tested as an assembly and should not be disassembled.

An ultrasonic weld rib is designed along the inner edge of the lens frame, as shown in Figure 6. This weld rib can be used to produce a bond via ultrasonic welding to the customer’s plastic enclosure bottom. Alternately, this bond can be successfully created with adhesives. Joint design will vary accordingly. Please reference additional Valencell documentation for more information.

The mechanical design has been optimized to reduce the impact of the sensor module on industrial design, specifically the sensor height into the device housing. Additionally, this sensor is design to “drop-in” to existing Benchmark 1.X customer products, with only a slight difference in total height. It is designed for easy integration into the bottom shell of a wristband, wristwatch, or armband with a portion of the module protruding into the interior of the wrist product and a portion protruding from the bottom of the wrist product as shown in Figure 6. This design balance provides optimal sensor accuracy with minimal disruption to other components of the interior of the product design.

For additional design and implementation guidelines, please-refer to the Benchmark Wrist Sensor Integration Guide and BW1.4 sensor drawing and models.

Figure 6: BW 1.4 Sensor Module Preliminary Drawing

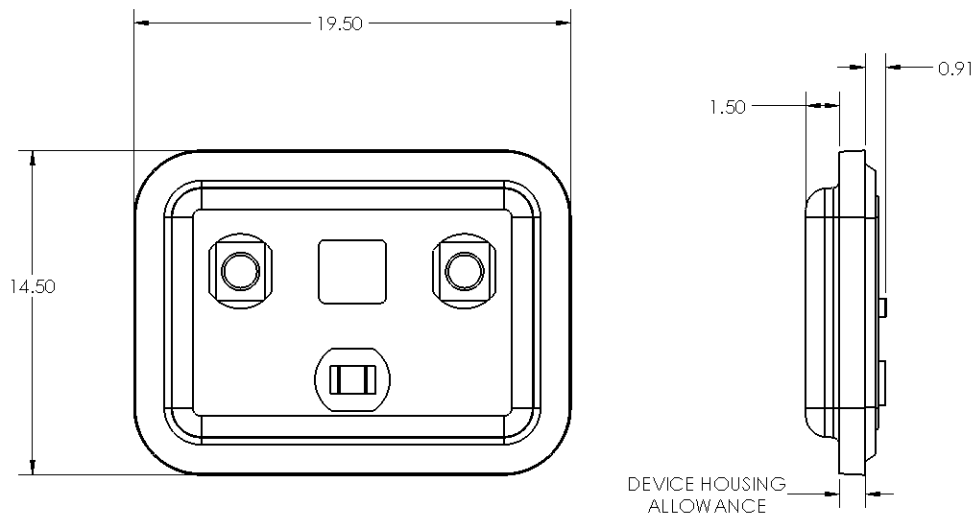

8 Processor Communication Interface Example

The BW1.4 sensor uses a slightly different I2C communication scheme compared to BW1.2. For details on the I2C differences, see the 001569 PerformTek Migration Guide Gen 1 to Gen 2.

An example of the processor communications interface protocol is described in short detail below. Simple packet-based commands are used to Get or Set measurement readings or parameters, or to control the PerformTek processor. For a full description of the interface protocol, please refer to the 000638 Valencell PerformTek Interface Protocol document.

- Command: Get(0x08)

The GET command issues requests for parameters and measured values from the PerformTek output registers. The purpose of these register values can range from declarations about the firmware features to the most recently calculated value for heart rate.

Following is an example of a GET command that requests three values (heart rate, step rate, and calories):

PerformTek Start	Byte Count	GET Command	BPM Request	SPM Request	CALS Request
0x44	0x04	0x08	0x20	0x30	0x42

- Command: Set (0x04)

The SET command writes configuration values to PerformTek registers. The purpose of these register values can range from declarations about the capability of the application, to information needed by the algorithms about the user.

Here is an example of a typical SET command that sends three user information parameters (age, gender, and weight):

PerformTek Start	Byte Count	SET Command	...					
0x44	0x0A	0x04	...					

age	34.5 years old		gender	female		weight	140 lbs	
0x10	0x01	0x9E	0x11	0x00	0x00	0x12	0x02	0x7B

Other interface commands control PerformTek processor operation. Full specifications of the API are available.

9 Sensor Ordering Guide

Part Number	Description
001842	Benchmark Wrist 1.4

10 Valencell Product Development Design and Test Services

Valencell has years of experience helping customers bring accurate biometric hearable and wearable devices to market. Much of our experience has been captured in application notes and in the integration and user guides, but additional design and test support is available upon request to help reduce your time to market and lower your technical development risks. Our support can span all stages of the product development process, from concept development through mass production and marketing. Design support examples include assisting with placement and mechanical integration of the sensor module within the product being worn; product fit and comfort; power-supply design; and audio design considerations for hearable designs.

Additionally, product performance should be backed by a solid test plan. Valencell has a sophisticated exercise and sport physiology test lab where products using our sensors are tested for proper performance. Our biometric sensors have been tested on thousands of test subjects with the statistical analysis done in a way that conforms to medical and sports journal publication standards. Testing is carried out both indoors and outdoors under many different activities with pools of subjects that have different skin tones, weight, hair, and fitness levels. Results from our sensor tests can be seen in the form of technical white papers on the Valencell website here: www.valencell.com/white-papers. Valencell Labs is located in the U.S. where there is a good diversity of test subjects. Our lab can validate the accuracy and performance of your product design and provide a statistical analysis as part of a design feedback report along with suggestions to improve the product design. This type of testing is the best and only way to know how well your product will perform when introduced into the market.

For more information about our support options, please contact Valencell.

11 Contact Information

For additional information please contact:

Sales Support: benchmark@valencell.com

Technical Support: support@valencell.com

A smaller version of the Valencell logo, with the word "VALENCCELL" and the stylized "C" symbol.

Valencell, Inc.

4601 Six Forks Rd. Suite 103

Raleigh, NC 27609

www.valencell.com

12 Statements

Valencell reserves the right to make changes to its products or example designs as part of its development program. This document and any other related support materials (collectively, the “Materials”) are intended to serve as resources only and users should not rely on them to ensure compliance with any laws or requirements.

Benchmark and PerformTek technology are not designed or authorized for use in life support, medical, or safety critical applications.

THE MATERIALS ARE PROVIDED "AS IS", WITHOUT WARRANTY OF ANY KIND, EXPRESS OR IMPLIED, INCLUDING BUT NOT LIMITED TO THE WARRANTIES OF MERCHANTABILITY, FITNESS FOR A PARTICULAR PURPOSE AND NONINFRINGEMENT. IN NO EVENT SHALL VALENCELL, INC., BE LIABLE FOR ANY CLAIM, DAMAGES OR OTHER LIABILITY, WHETHER IN AN ACTION OF CONTRACT, TORT OR OTHERWISE, ARISING FROM, OUT OF OR IN CONNECTION WITH THE MATERIALS.

No license is granted or implied under any patent or other rights owned by Valencell, Inc., by the publication or transfer of the information contained herein. Unless otherwise stated, words and logos marked with ® or ™ are trademarks registered or owned by Valencell, Inc. Other products, services and names used in this document may have been trademarked by their respective owners.

Patent Notice:

Protected by granted patents and/or patents pending: www.valencell.com/patents

Both Benchmark® and PerformTek® and the Benchmark and PerformTek designs are registered trademarks of Valencell, Inc. and may not be used for any purpose without the express prior written consent of Valencell, Inc.