

## Benchmark™ Biometric Sensor System for Wearable Devices

### Features

- Market-leading optical heart rate (HR) measurement, HR zone, HR recovery, resting HR, step rate / count, distance cycling cadence, calories, VO<sub>2</sub>, at-rest R-R interval (RRi) and activity recognition (running/lifestyle).

\*Note: Sensor measures P-P interval which correlates with RRi, see Valencell Heart Rate Variability Review for more information

- Benchmark™ sensor and processor provided separately for direct system integration to provide flexibility and minimize space impact to the wearable design
- Sensor module contains LED, detector, and accelerometer mounted to a window assembly optimized for sensor system accuracy
- PerformTek™ Low-Power ARM® Cortex® processor performs sensor data processing and provides a communication interface to the system host processor.

Figure 1: Benchmark™ Wrist 2.0 Processor and Sensor



- Wrist Sensor Dimensions: (15.2 x 13.6 x 2.4) mm
- Processor Package: WLCSP-49, 0.4 mm pitch, (3.0 x 3.0 x 0.4) mm
- Sensor Weight: 0.42 grams
- 400 kHz I2C or 57.6 kbps UART Interface
- Processor V<sub>DD</sub>: 1.8 VDC to 3.3 VDC
- Sensor V<sub>DD(SENSE)</sub>: 1.8 VDC to 3.3 VDC
- Sensor V<sub>LED</sub>: 5 VDC
- V<sub>DD</sub> Current: 1.54 mA standard operating; 5 uA Standby mode; 1 mA in Idle mode

- V<sub>DD(SENSE)</sub> Current: 0.06 mA standard operating
- V<sub>LED</sub> Current: 0.46 mA standard operating
- Field updatable processor firmware
- Patented optomechanical designs
- 100% factory-tested optical and sensor performance
- Additional design and test services available upon request

### Description

The PerformTek™ powered Benchmark™ Wrist 2.0 Sensor System is the next-generation biometric sensor technology developed by Valencell, Inc. This sensor module supports higher resolution measurements and is approximately 30% smaller than our first-generation sensor. This sensor plus the PerformTek™ processor helps you quickly develop your own biometric wearable products. The modular design brings together the best available parts of a successful biometric sensor system in a smaller form factor and includes emitter/detector sensor electronics in an optimized optical package with a processor that is pre-programmed with Valencell's PerformTek™ advanced biometric algorithms.

Figure 2: Benchmark™ Wrist 2.0 Simplified Block Diagram

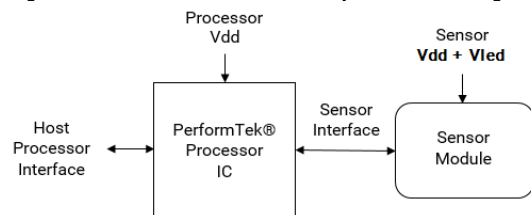

### Applications

- Wearable Devices / Lifestyle / Activity Bands
- Smart Watches
- Wrist, Forearm, and Upper Arm Bands for Sports
- Helmets and Headbands

## Reference Documentation

Table 1: Related Documents

Document	Title
000638	PerformTek™ Interface Protocol Document
000964	PerformTek™ User Guide
000832	PerformTek™ Wrist Integration Guide
000982	Benchmark™ BW2.0 Sensor Drawing and 3D CAD models
001113	Valencell Heart Rate Variability Review

## Change Record

Table 2: Change Record

Author	Revision	Date	Description of change(s)
MEP	1.00	15APR2017	Initial Release
MEP	1.01	26MAY2017	<ul style="list-style-type: none"> <li>- Clarified NRST connection when not driven by Host</li> <li>- Clarified Sensor and MCU current “Conditions” description in Tables 6 and 9.</li> <li>- Added power sequencing information Section 5.2</li> <li>- Performed minor editorial changes</li> </ul>

---

## Table of Contents

1	Block Diagram / System Overview .....	4
1.1	Overview .....	4
2	Pin Descriptions .....	5
2.1	Sensor Pinout .....	5
2.2	PerformTek™ Processor Pin Description.....	6
3	Electrical Characteristics .....	9
3.1	Sensor.....	9
3.2	PerformTek™ Processor .....	11
4	PerformTek™ Processor Integration .....	13
4.1	PerformTek™ Processor Schematic .....	13
4.2	PerformTek™ Processor Connections .....	14
5	Power Supply Design Guidelines .....	17
5.1	Power Supply Loading .....	17
5.2	Power Supply Sequencing.....	18
6	Sensor Optical-Mechanical Integration.....	19
7	Processor Communication Interface Example.....	21
8	Sensor Ordering Guide and Comparison Chart .....	22
9	Incoming QC Module Test Fixture.....	23
10	Valencell Product Development Design and Test Services .....	24
11	Contact Information .....	25
12	Statements .....	26

# 1 Block Diagram / System Overview

Figure 3: Benchmark™ Wrist 2.0 Functional Block Diagram

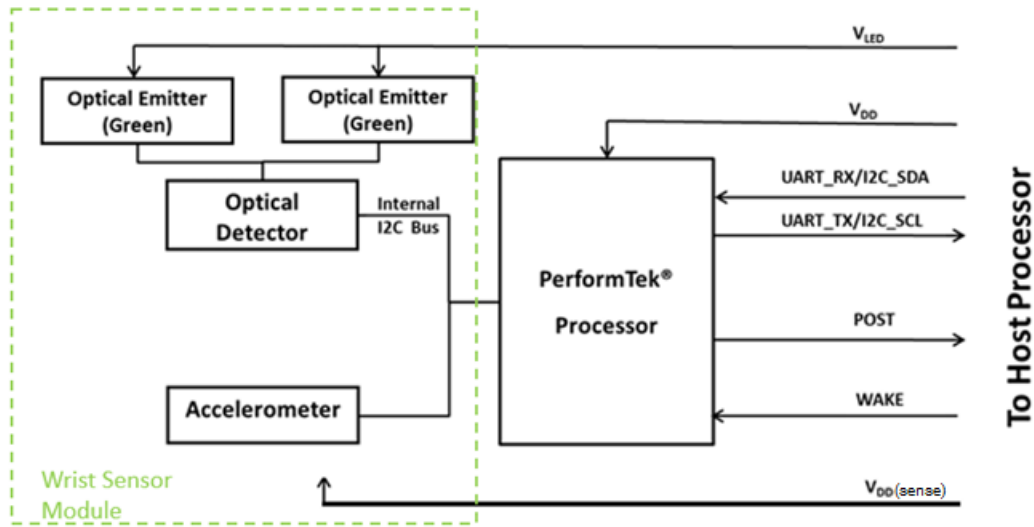

## 1.1 Overview

The Benchmark™ Wrist 2.0 Biometric Sensor solution is provided in two pieces, the sensor and the PerformTek™ processor. Figure 3 shows how these pieces work together and is described below.

On the left of the diagram, the sensor module circuit board contains a digital optical detector system, two LEDs, and an accelerometer. The detector, LEDs, and accelerometer work together to collect biometric information via reflected light and movement from the wearer. This information is transmitted over the I2C bus when requested by the PerformTek™ processor.

The PerformTek™ processor collects the sensor data and runs Valencell’s patent protected algorithms to convert the raw measurements into biometric values such as heart rate or cadence and processes those values further into higher level user assessments like calories burned. In addition, sensor module diagnostics such as signal quality, error codes, and serial number ID are available. This information is available to the Host processor via the Host Interface.

The Host Interface is shown on the right side of the diagram. Control lines for interfacing the host processor with the PerformTek™ processor include UART or I2C, Power-On Self-Test (POST), and a Wake-from-Standby line (WAKE). More details on this interface are provided in Section 4.2.

## 2 Pin Descriptions

### 2.1 Sensor Pinout

Table 3 shows the pinout for the sensor. Figure 4 shows the sensor solder pads that are provided for individual wire or custom flex cable connection. See the BW2.0 Sensor Drawing for more details.

Table 3: Sensor Pinout

Pin Number	Symbol	Description
1	V <sub>LED</sub>	5.0 VDC Power. Connect to V <sub>LED</sub> supply voltage
2	V <sub>DD(SENSE)</sub>	1.8 to 3.3 VDC Sensor Power. Connect to sensor supply voltage
3	GND	Connect to system ground / reference plane
4	SDA	I2C Data Line. Connect to PerformTek™ Processor
5	SCL	I2C Clock Line. Connect to PerformTek™ Processor

Figure 4: Sensor Drawing with Solder Pads

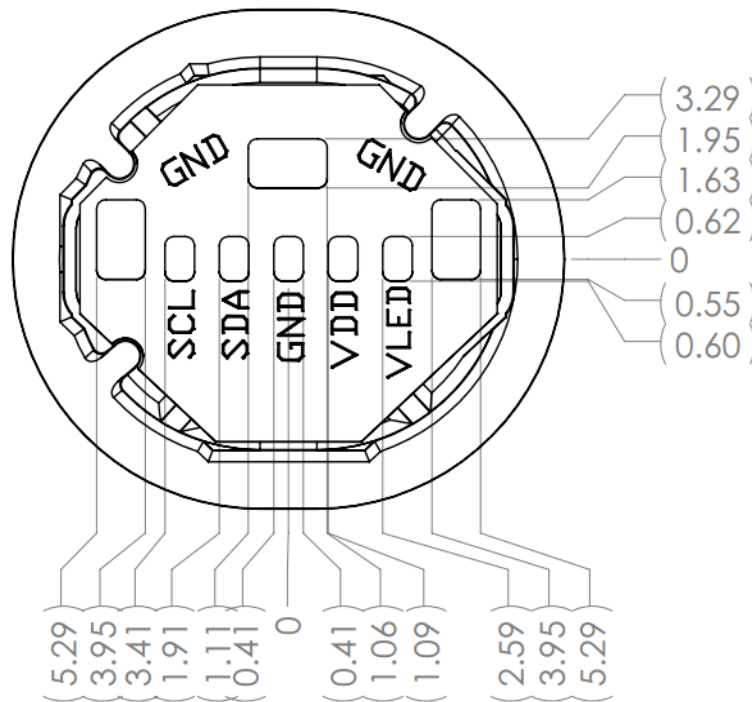

## 2.2 PerformTek™ Processor Pin Description

Table 4 provides a description of the pin assignments to the PerformTek™ processor. Pins that are not listed are not connected in the current design implementation. See the STMicroelectronics STM32F401CCY6 device datasheet for processor package information.

**Table 4: Processor Pinout**

Pin	Name	I/O	Description
A4	SDA	I/O	Sensor I2C data pin. Connect this pin to the sensor I2C bus. A pullup is required on this pin. A series zero ohm resistor should be added to this signal to enable Valencell debug support.
A5	GND	Power	Connect to system ground / reference plane
A6	GND	Power	Connect to system ground / reference plane
A7	V <sub>DD</sub>	Power	Connect to processor supply voltage
B1	GND	Power	Connect to system ground / reference plane
B2	V <sub>DD</sub>	Power	Connect to processor supply voltage
B6	PDR_ON	I	Enables processor internal power-on reset. Connect to the processor supply voltage to ensure proper startup of the processor.
B7	VBAT	I	Connect this pin to V <sub>DD</sub> along with a 0.1uF decoupling capacitor to GND. Do NOT connect to battery voltage.
C4	Host TX/SCL	I/O	Host interface pin configured as either UART TX (processor output) or I2C SCL depending on the selected communication protocol. A pull-up resistor should be added for I2C operation. Connect this pin to the host processor. A series zero ohm resistor should be added to this signal to enable Valencell debug support.
D1	SCL	I/O	Sensor I2C clock pin. Connect this pin to the sensor I2C bus. A pullup is required on this pin. A series zero ohm resistor should be added to this signal to enable Valencell debug support.
D3	GND	Power	Connect to system ground / reference plane

Pin	Name	I/O	Description
D4	RX/SDA	I/O	Host interface pin configured as either UART RX (processor input) or I2C SDA depending on the selected communication protocol. A pull-up resistor should be added for I2C operation. Connect this pin to the host processor. A series zero ohm resistor should be added to this signal to enable Valencell debug support.
D6	OSC OUT	O	Crystal oscillator output. For information on selecting the crystal, refer to the microcontroller specification and the application note AN2867 "Oscillator design guide for ST microcontrollers" available from the ST website <a href="http://www.st.com">www.st.com</a> .
D7	OSC IN	I	Crystal oscillator input
E2	COM Sel	I	Connect to processor supply voltage for I2C Host Interface communication and to system ground for UART communication.  Note: For legacy designs that cannot appropriately drive this pin, see the description of the AutoComms feature in Section 4.2.
E6	GND	Power	Connect to system ground / reference plane
E7	NRST	I	Processor reset. A logic low on this pin will reset the processor.
F2	V <sub>DD</sub>	Power	Connect to processor supply voltage
F6	WAKEUP	I	Wakeup signal from host processor. A low-to-high transition on this pin will wake the processor from Standby  Note: The processor will not enter Standby if this signal is not low.
G2	VCAP	I	Connect this pin to GND via a 4.7uF capacitor

Pin	Name	I/O	Description
G4	POST	I/O	<p>This pin serves two functions:</p> <ol style="list-style-type: none"> <li>1. Power-On Self Test Output: This pin will present a logic high after the power up process has successfully completed.</li> <li>2. Bootloader Mode Input: Driving the POST pin high during boot up puts the device into bootloader mode. The POST pin should not be biased during normal operation.</li> </ol>



### 3 Electrical Characteristics

#### 3.1 Sensor

Table 5: Recommended Operating Conditions for Sensor

Parameter	Symbol	Conditions	Min	Typ	Max	Units
V <sub>LED</sub> Supply Voltage	V <sub>LED</sub>	Min and Max are inclusive of V <sub>LED</sub> ripple requirement	4.875	5.0	5.50	VDC
V <sub>LED</sub> Ripple voltage_30k	V <sub>ripple_10</sub>	Sensor system active: 0 to 30 kHz Ripple	---	---	250	mV <sub>pp</sub>
V <sub>LED</sub> Ripple voltage_100M	V <sub>ripple_100</sub>	Sensor system active: >30 kHz to 100 MHz Ripple	---	---	100	mV <sub>pp</sub>
Sensor Supply Voltage	V <sub>DD(SENSE)</sub>	Min and Max are inclusive of V <sub>DD</sub> ripple requirement	1.76	3.3	3.6	VDC
Sensor Supply Ripple Voltage_10	V <sub>ripple_10</sub>	Sensor system active: 0 to 10 MHz Ripple	-	-	50	mV <sub>pp</sub>
Sensor Supply ripple voltage_100	V <sub>ripple_100</sub>	Sensor system active: >10 MHz to 100 MHz Ripple	-	-	100	mV <sub>pp</sub>
Operating Temperature	-	Device operating in Standby, Idle, or Active Modes	-10	25	50	°C

Table 6: Operating Characteristics of Sensor

Parameter	Symbol	Conditions	Min	Typ	Max	Units
I <sub>DD</sub> + I <sub>LED</sub> Sensor OFF Mode	-	No V <sub>DD</sub> supply given to sensor module	-	0	-	μA
I <sub>DD</sub> + I <sub>LED</sub> Sensor Standby and Idle Modes	-	System is in Standby mode	-	5	32	μA

Parameter	Symbol	Conditions	Min	Typ	Max	Units
I <sub>DD</sub> Sensor Active Mode with Standard-Precision RRi	-	System is in Active mode and operating at standard RRi sampling rate	-	0.061	-	mA
I <sub>DD</sub> Sensor Active Mode with High-Precision RRi	-	System is in Active mode and operating at fast RRi sampling rate	-	0.248	-	mA
I <sub>DD</sub> Sensor Active Mode with Best-Precision RRi	-	System is in Active mode and operating at fastest RRi sampling rate	-	0.482	-	mA
I <sub>LED</sub> Sensor Active Mode with Standard-Precision RRi	-	System is in Active mode and operating at standard RRi sampling rate	-	0.461	0.580	mA
I <sub>LED</sub> Sensor Active Mode with High-Precision RRi	-	System is in Active mode and operating at fast RRi sampling rate	-	2.30	2.88	mA
I <sub>LED</sub> Sensor Active Mode Best-Precision RRi	-	System is in Active mode and operating at fastest RRi sampling rate	-	4.61	5.77	mA
I <sub>LED</sub> Sensor Pulse Current	I <sub>pulse</sub>	System is in Active mode	-	39	49	mA

Absolute limits are provided below. If these limits are exceeded, permanent device damage may occur.

Additionally, if the sensor is exposed to these limits for an extended period of time, the sensor reliability may be impacted.

Table 7: Sensor Absolute Maximum Limits

Parameter	Symbol	Conditions	Min	Typ	Max	Units
Operating Temperature	-	Device operating in Standby, Idle, or Active Modes – performance not guaranteed	-20	-	70	°C

Storage Temperature	-	Device powered off, device will require time to equalize with normal operating temperature after exposure to limits of storage temperature	-50	-	85	°C
ESD Rating	-	Human Body Model <sup>1</sup>	-	-	2	kV

Note 1: The sensor module is designed to support system level ESD compliance testing up to 15 kV; however, ESD protection for the standalone sensor module is intended only to protect the sensor during normal handling in a typical electronic manufacturing environment with typical ESD protection in place.

### 3.2 PerformTek™ Processor

PerformTek™-specific and high-level processor characteristics are provided below. See the processor datasheet for more details.

**Table 8: Recommended Operating Conditions for PerformTek™ Processor**

Parameter	Symbol	Conditions	Min	Typ	Max	Units
Processor Supply Voltage <sup>1 2</sup>	V <sub>DD</sub>	Processor internal Power-On Reset Enabled	1.76	3.3	3.6	V

Note 1: The processor may be operated at 1.80 VDC, with the sensor at 3.3 VDC; however, I2C pullup resistors for the bus between them should be tied to 3.3 VDC to ensure logic level compatibility.

Note 2: V<sub>DD</sub> must reach or exceed 1.80 VDC on startup to ensure that the internal Processor's Power-On Reset appropriately de-asserts and must stay above 1.76 VDC during operation to avoid Power-Down Reset Assertion. See ST Micro STM32F401x datasheet for more details.

**Table 9: Operating Characteristics of PerformTek™ Processor**

Parameter	Symbol	Conditions	Min	Typ	Max	Units
I <sub>DD</sub> Idle Mode	-	System is in Idle mode	-	0.95	-	mA
I <sub>DD</sub> Standby Mode	I <sub>STBY</sub>	System is in Standby mode	-	5	-	μA

Parameter	Symbol	Conditions	Min	Typ	Max	Units
I <sub>DD</sub> Active Mode with Standard-Precision RRi <sup>2</sup>	-	System is in Active mode and operating at standard RRi sampling rate	-	1.54 to 1.99	-	mA
I <sub>DD</sub> Active Mode with High-Precision RRi <sup>1,2</sup>	-	System is in Active mode and operating at fast RRi sampling rate	-	1.90 to 2.35	-	mA
I <sub>DD</sub> Active Mode with Best-Precision RRi <sup>1,2</sup>	-	System is in Active mode and operating at fastest RRi sampling rate	-	2.45 to 2.90	-	mA
I <sub>DD</sub> Processor Pulse Current	I <sub>pulse</sub>	System is in Active mode	-	10	-	mA
Start-up time before POST response	t <sub>POST</sub>	On Start-up, time measured after V <sub>DD</sub> equal to or above 1.8V	-	40	150	ms

Note 1: Standard-, High-, and Best-Precision typical ranges depend on if an external oscillator is utilized or not. The external oscillator will further increase precision but will also increase power consumption.

Note 2: High- and Best- precision operation and current draw applies to RRi only. Best-precision heart rate monitoring is available in standard Active Mode.

## 4 PerformTek™ Processor Integration

### 4.1 PerformTek™ Processor Schematic

The included PerformTek™ Processor is based on the STMicroelectronics STM32F401CCY6. The processor is programmed by Valencell, Inc. with PerformTek™ custom firmware and algorithms. To interface with this programmed processor, please utilize the schematic diagram and associated interface descriptions that follow. For additional electrical and physical specifications for this processor consult the STM32F401CCY6 datasheet and associated documentation available at [www.st.com](http://www.st.com) or contact your local STMicroelectronics sales representative.

Figure 5: Processor Connection Schematic (I2C Host Connection Shown)

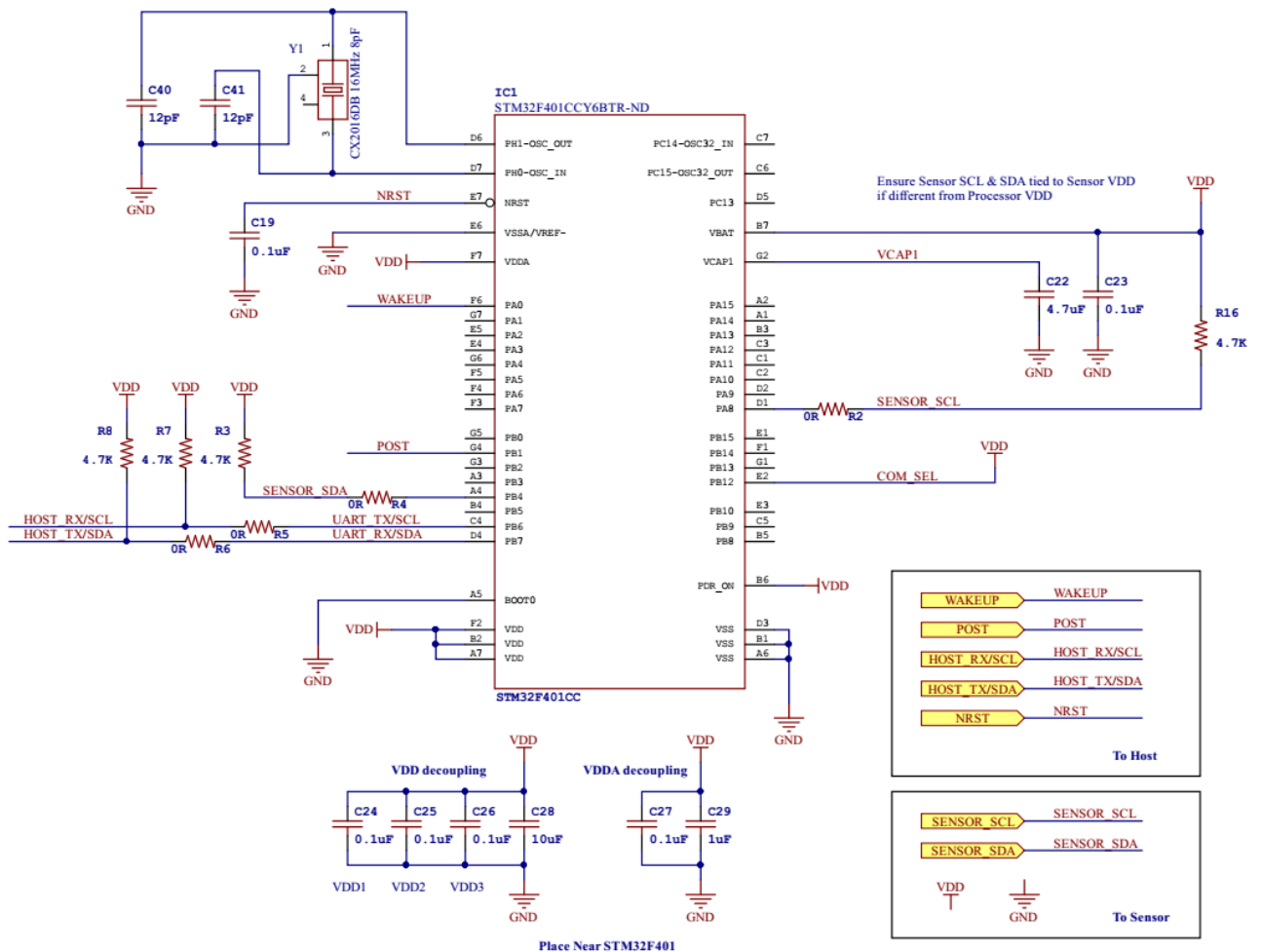

## 4.2 PerformTek™ Processor Connections

- Host Interface – UART / I2C

The Host Interface that connects the system processor to the PerformTek™ processor supports both I2C and UART communications. This should be selected by tying the COM\_SEL pin to V<sub>DD</sub> for I2C or Ground for UART communications. While it is recommended that COM\_SEL be actively driven to select I2C or UART communications, the processor also provides an automatic communication protocol (AutoComms) selection feature if COM\_SEL is not connected. With this feature, the processor monitors its UART\_TX pin by applying a weak pull-down to this pin and then reading its status. If the pin is pulled high, it enters I2C communications mode, and if the pin is low, it enters UART communications mode.

Figure 6: AutoComms Compatible Signal Configurations

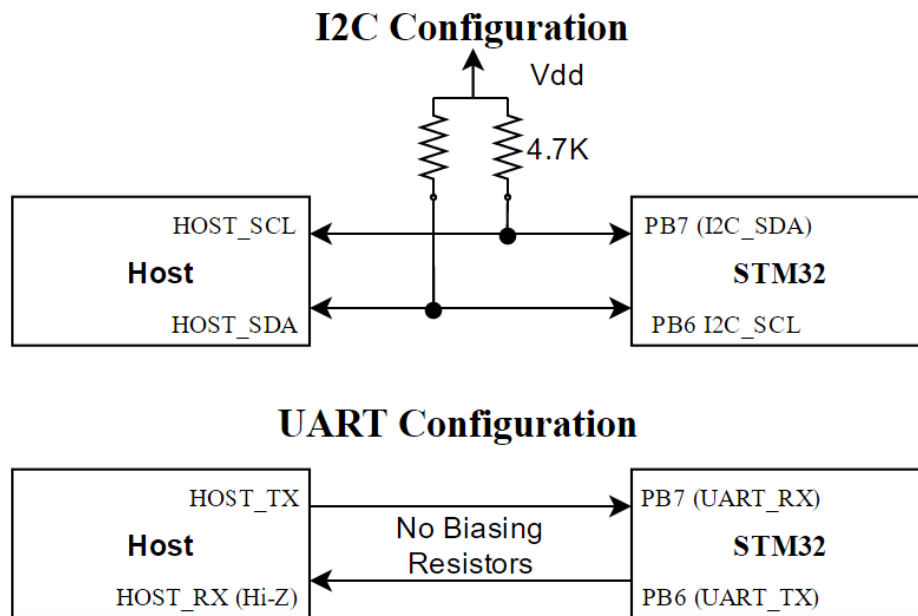

For proper AutoComms functionality, follow these steps:

- For a UART interface, no biasing should be added to the communication lines. For I2C, typical pull-up resistor values should be connected between the I2C lines and the Host interface V<sub>DD</sub>.
- During PerformTek™ processor bootup, the communication lines should not be driven by the host processor until either the POST pin goes high or t<sub>POST</sub> as defined in Table 9 has elapsed.

For UART host communications, the UART\_RX pin is the receive line for data sent to the module from the host processor and the UART\_TX pin is the transmit line from the sensor module to the host. The port settings are 57.6 kbps, 8, N, 1. There is no hardware or software flow control.

For I2C host communications, the I2C\_SDA line is the data line and I2C\_SCL line is the clock line. The sensor module acts as an I2C slave device with a 400KHz bus speed and an I2C address of 0x44.

For information about the UART or I2C communication protocols, see the PerformTek™ Interface Protocol Document.

- Host Interface – POST (Power-On Self-Test)

Once  $V_{DD}$  power is applied, the processor will attempt to initialize all components on the module. This startup time is defined by  $t_{POST}$  in Table 9. If startup is successful, the POST pin will assert high, otherwise, the pin will stay low. If the POST pin is not utilized, the Max time for  $t_{POST}$  should be observed before interaction with the PerformTek™ processor begins.

Diagnostic information associated with this pin is stored in the sensor module's registers and can be read via the UART/ I2C Host Interface. As part of the POST, the PerformTek processor tests communications with the sensor peripherals and exercises the axes of the accelerometer while checking for a response within bounds. If a failure is detected but the processor can still communicate, the POST will still assert high. To ensure correct system operation, the POST register should be examined at startup. Refer to the PerformTek™ Interface Protocol Document for further information on the POST and other diagnostic registers.

- Host Interface – WAKE

WAKE is an input to the module used to bring the module out of Standby mode. Raising this pin from Low to High will return the module to an awake state, ready for communication.

Note that lowering WAKE does not put the module into Standby mode. Low-Power Standby mode is entered via a command over the UART/ I2C module communications. WAKE pin should be lowered before issuing the Standby command. If this pin is not used, it may be tied high to  $V_{DD}$ , but this will prevent the module from entering Standby mode.

- I2C Sensor Interface

The I2C sensor bus (I2C3) requires pullup resistors to  $V_{DD(SENSE)}$ . Typical pullup resistor values are shown but may require adjustment depending on your system configuration.

- Crystal Oscillator

The crystal configuration is used for high accuracy applications and may be omitted for power and space savings when additional inaccuracies from the processor's HSI oscillator can be tolerated. If included, a 16MHz crystal, such as the Kyocera CX2016DB, should be used to maintain software compatibility.

For more information about the processor's HSI accuracy, see the ST Micro STM32F401x datasheet for more details. For information on selecting the crystal, refer to the microcontroller specification and the application note AN2867 "Oscillator design guide for ST microcontrollers" available from the ST website [www.st.com](http://www.st.com).

- NRST

NRST is an active low reset signal connected to the HOST controller to allow it to control reset of the PerformTek™ processor. Valencell recommends connecting this line to the Host controller as part of a robust system reset strategy. However, if this cannot be done, NRST should be tied to a 0.1 μF capacitor placed close to the NRST processor pin as shown in Figure 5.

Note: Current consumption is undefined while the PerformTek processor is held in reset. NRST should not be used as a method to hold the PerformTek processor in a low power state. Standby mode is the best method for achieving minimum power consumption.

- Decoupling

The capacitors shown in Figure 5 are necessary to reduce noise and ensure measurement accuracy and proper processor functionality. These capacitors should be placed physically near the V<sub>DD</sub> pins of the processor.

- Firmware Updates

The PerformTek™ processor supports in-field firmware updates via the Host Interface. Driving the PerformTek™ processor's POST pin high during boot up puts the device into bootloader mode. The POST pin should not be biased during normal operation. Refer to the PerformTek™ User Guide for further information on this feature.



## 5 Power Supply Design Guidelines

### 5.1 Power Supply Loading

The PerformTek™ processor and sensor may be supplied from the same rail ( $V_{DD}$  and  $V_{DD(SENSE)}$  combined) or may be supplied separately. If they are supplied together, care must be taken to ensure that the voltage tolerances and ripple specifications for the sensor are still followed. The system power supply or supplies should be designed to meet the requirements in Section 3 during transients from both the Benchmark™ sensor and processor.

Peak  $V_{LED}$  current will be periodic where the period of the peaks will depend on the mode of operation Heart Rate and Standard-Precision RRI (40 ms), High-Precision RRI (8 ms), and Best-Precision RRI (4 ms). A typical current peak profile for sensor  $V_{LED}$  is shown in Figure 7.

Figure 7: Typical Benchmark™ Sensor Current Pulse

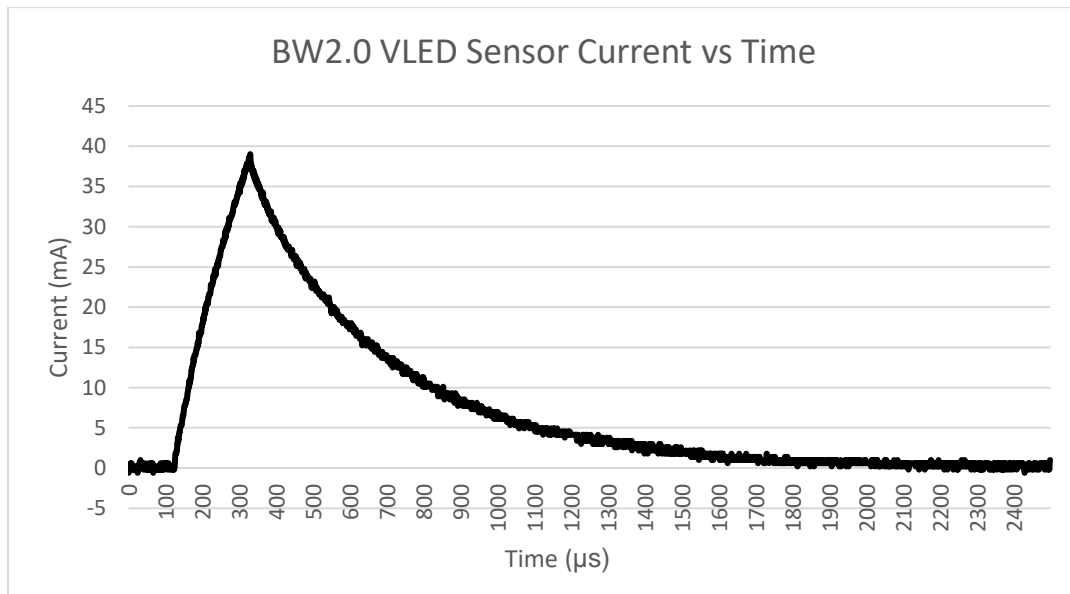

The  $V_{LED}$  current profile shown here and the  $V_{LED}$  and  $V_{DD}$  current peaks listed in Section 3 are based on measured system performance. Processor  $V_{DD}$  current peaks are of smaller amplitude and much smaller duration than  $V_{LED}$  current peaks and  $V_{DD(SENSE)}$  current peaks are negligible. Actual peak and average  $V_{DD}$  processor current peak and average numbers will vary depending on the unique characteristics of the system design and how the PerformTek™ features are used within the system. Because of this, Valencell recommends testing our sensors in a manner representative of their intended use as early as possible in

---

the design cycle. To facilitate this, Valencell supplies development kits that support early prototyping and power measurement and can provide design support and review services upon request.

## 5.2 Power Supply Sequencing

The system  $V_{LED}$  supply should come up at the same time or before the  $V_{DD}$  supply to ensure correct sensor operation. This requirement is met if  $V_{LED} = 1.4 \text{ V}$  ( $0.77 \times V_{DD}$ ) at the same time or before  $V_{DD} = 1.8 \text{ V}$  on initial power up.

## 6 Sensor Optical-Mechanical Integration

The optical lens system is a critical component of the sensor module, ensuring good optical coupling from the emitters and sensors to the user's skin. This is necessary for accurate measurement. The lens frame is an overmolded PC/ABS opaque frame onto an optical grade film lens. The PCB and opto-mechanical lens is tested as an assembly and should not be disassembled.

Figure 8: Wrist Sensor Drawing (For Reference Only)

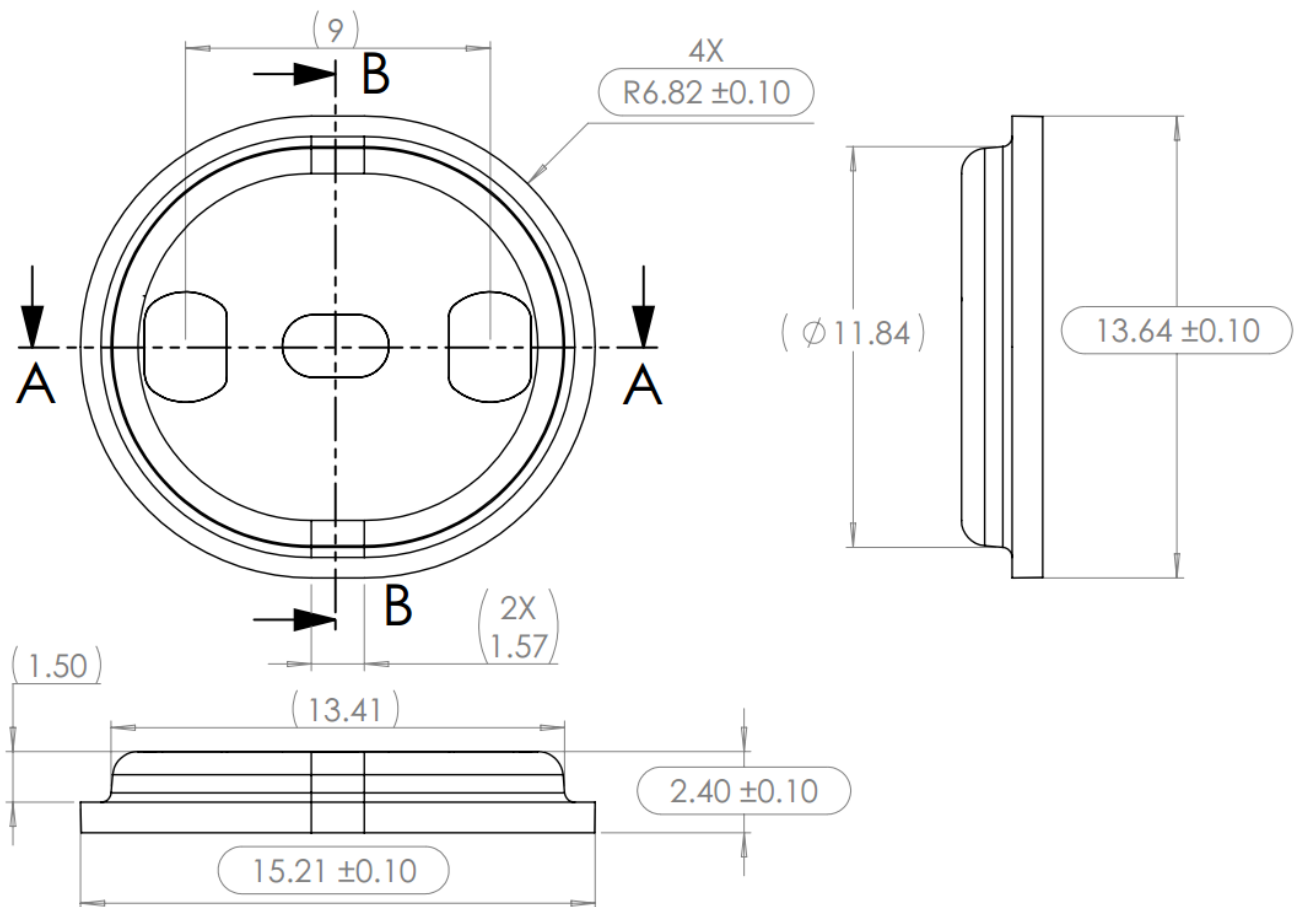

The mechanical design has been optimized to reduce the impact of the sensor module on industrial design, especially in total sensor height when built into the device housing. It is designed for easy integration into the bottom shell of a wristband, wristwatch, or armband with part of the module protruding into the interior of the wrist product and part protruding from the bottom of the wrist product. This design balance provides optimal sensor accuracy with minimal disruption to other components of the interior of the product design.

The BW2.0 sensor may be integrated with a glue joint or with an ultrasonic weld. To achieve the thinnest possible profile, the BW 2.0 sensor does not provide an energy director to support ultrasonic welding. For ultrasonic weld assembly, an energy director may be added to the mating assembly.

For additional capture feature design and adhesive process guidelines and more complete details on sensor integration refer to the 000832 Benchmark™ Wrist Sensor Integration Guide and 000982 BW2.0 Sensor 3D CAD models and drawings.

## 7 Processor Communication Interface Example

An example of the processor communications interface protocol is described in short detail below. Simple packet based commands are used to Get or Set measurement readings or parameters, or to control the PerformTek™ processor. For a full description of the interface protocol, please refer to the 000638 Valencell PerformTek™ Interface Protocol document.

- Command: Get(0x08)

The GET command issues requests for parameters and measured values from the PerformTek™ output registers. The purpose of these register values can range from declarations about the firmware features to the most recently calculated value for heart rate.

Following is an example of a GET command that requests three values (heart rate, step rate, and calories):

PerformTek™ Start	Byte Count	GET Command	BPM Request	SPM Request	CALS Request
0x44	0x04	0x08	0x20	0x30	0x42

- Command: Set (0x04)

The SET command writes configuration values to PerformTek™ registers. The purpose of these register values can range from declarations about the capability of the application, to information needed by the algorithms about the user.

Here is an example of a typical SET command that sends three user information parameters (age, gender, and weight):

PerformTek™ Start	Byte Count	SET Command	...
0x44	0x0A	0x04	...

...	age	34.5 years old		gender	female		weight	140 lbs	
...	0x10	0x01	0x9E	0x11	0x00	0x00	0x12	0x02	0x7B

Other interface commands control PerformTek™ processor operation. For full specifications, consult the PerformTek™ Interface Protocol document.

## 8 Sensor Ordering Guide and Comparison Chart

Part Number	Description
000945	Benchmark™ Ear 2.0
000915	Benchmark™ Ear 1.2
001034	Benchmark™ Wrist 2.0
000954	Benchmark™ Wrist 1.2

## 9 Incoming QC Module Test Fixture

Benchmark™ sensors are 100% optically tested at the factory using a Valencell-designed VIPER test fixture. As an option, these VIPER test fixtures are available for customers to use as part of their incoming inspection process. The test fixtures are available for purchase – please contact Valencell, Inc. for pricing, availability, and additional details.

---

## 10 Valencell Product Development Design and Test Services

Valencell has years of experience helping customers bring accurate biometric hearable and wearable devices to market. Much of our experience has been captured in application notes and in the integration and user guides, but additional design and test support is available upon request to help reduce your time to market and lower your technical development risks. Our support can span all stages of the product development process, from concept development through mass production and marketing. Design support examples include assisting with placement and mechanical integration of the sensor module within the product being worn; product fit and comfort; power-supply design; and audio design considerations for hearable designs.

Additionally, product performance should be backed by a solid test plan. Valencell has a sophisticated exercise and sport physiology test lab where products using our sensors are tested for proper performance. Our biometric sensors have been tested on thousands of test subjects with the statistical analysis done in a way that conforms to medical and sports journal publication standards. Testing is carried out both indoors and outdoors under many different activities with pools of subjects that have different skin tones, weight, hair, and fitness levels. Results from our sensor tests can be seen in the form of technical white papers on the Valencell website here: [www.valencell.com/white-papers](http://www.valencell.com/white-papers). Valencell Labs is located in the U.S. where there is a good diversity of test subjects. Our lab can validate the accuracy and performance of your product design and provide a statistical analysis as part of a design feedback report along with suggestions to improve the product design. This type of testing is the best and only way to know how well your product will perform when introduced into the market.

For more information about our support options, please contact Valencell.



## 11 Contact Information

*For additional information please contact:*

Sales Support: [benchmark@valencell.com](mailto:benchmark@valencell.com)

Technical Support: [support@valencell.com](mailto:support@valencell.com)



Valencell, Inc.

4601 Six Forks Rd. Suite 103

Raleigh, NC 27609

[www.valencell.com](http://www.valencell.com)

## 12 Statements

Valencell reserves the right to make changes to its products or example designs as part of its development program. This document and any other related support materials (collectively, the “Materials”) are intended to serve as resources only and users should not rely on them to ensure compliance with any laws or requirements.

Benchmark™ and PerformTek™ technology are not designed or authorized for use in life support, medical, or safety critical applications.

THE MATERIALS ARE PROVIDED "AS IS", WITHOUT WARRANTY OF ANY KIND, EXPRESS OR IMPLIED, INCLUDING BUT NOT LIMITED TO THE WARRANTIES OF MERCHANTABILITY, FITNESS FOR A PARTICULAR PURPOSE AND NONINFRINGEMENT. IN NO EVENT SHALL VALENCELL, INC., BE LIABLE FOR ANY CLAIM, DAMAGES OR OTHER LIABILITY, WHETHER IN AN ACTION OF CONTRACT, TORT OR OTHERWISE, ARISING FROM, OUT OF OR IN CONNECTION WITH THE MATERIALS.

No license is granted or implied under any patent or other rights owned by Valencell, Inc., by the publication or transfer of the information contained herein. Unless otherwise stated, words and logos marked with ® or ™ are trademarks registered or owned by Valencell, Inc. Other products, services and names used in this document may have been trademarked by their respective owners.

**Patent Notice:**

Protected by granted patents and/or patents pending: [www.valencell.com/patents](http://www.valencell.com/patents)

Both Benchmark™ and PerformTek™ and the Benchmark™ and PerformTek™ designs are registered trademarks of Valencell, Inc. and may not be used for any purpose without the express prior written consent of Valencell, Inc.